

air.IQ

Moisture analyzer packaged solution

air.IQ simplifies the selection and installation of your moisture analyzer. Install the moisture probe, wire your power and outputs to the terminal strip, and connect your gas to the inlet fitting.

- Wall mounted NEMA 4X package
- Includes the analyzer display, moisture probe, interconnecting cable, and sample system
- Features the dew.IQ moisture analyzer
- The IQ.probe makes installation and start-up easy
- Sample system provides isolation, filtration, pressure and flow indication, pre-wired, and a clear door for easy viewing of all readings

Ordering configuration

air.IQ is comprised of the following items:

- DEW.IQ-3-6-1-0
- IQ.PROBE-2-W-0-0-0-0
- 733-1155-00

Application parameters

- Inert gases such as air, nitrogen, SF6
- Sample gas pressure: 0 to 200 psig
- Sample gas temperature: 0 to +50 C
- Moisture content: -110 to +20 C dew/frost point, non-condensing
- Power requirements: 100 - 240 VAC @ 50 - 60 Hz

Applications

The standard air.IQ package is designed for moisture measurement in any inert gas application, in industrial environments classified as safe areas, where the process gas pressure is slightly positive to a maximum of 200 psig. It combines the Panametrics dew.IQ and IQ.probe with 50 years of sample system design, to deliver the moisture measurement you have come to trust.

Markets and applications served include:

- Industrial gas
- Air dryer/clean dry air
- Plastics drying
- Pharmaceutical
- Aerospace
- Power generation

Technical Specifications*

IQ.probe

Sensor type	Thin-film aluminum oxide
Dew/frost point temperature	<ul style="list-style-type: none"> • Overall range capability: -110° to 60°C (-166° to 140°F) • Standard: -80° to 20°C (-112° to 68°F) with data to -110°C (-166°F)
Calibrated accuracy at 77°F (25°C)	<ul style="list-style-type: none"> • ±3.6°F (±2°C) above -148°F (-100°C) • ±5.4°F (±3°C) below -148°F (-100°C)
Repeatability	<ul style="list-style-type: none"> • ±0.4°F (±0.2°C) above -148°F (-100°C) • ±0.9°F (±0.5°C) below -148°F (-100°C)

dew.IQ

European certification	Complies with EMC directive 2004/108/EC and 2006/95/EC low voltage directive (installation category II, pollution degree II)
Input	Moisture signal from an M series probe or IQ.probe
Analog output	Single internal isolated recorder output, internally optically isolated, 10-bit (0.1%) resolution
Switch-selectable outputs	<ul style="list-style-type: none"> • 0 to 2 V, 10k Ω minimum load resistance • 0 to 20 mA, 400 Ω maximum series resistance • 4 to 20 mA, 400 Ω maximum series resistance • User-programmable within the range of the instrument and the corresponding sensor or transmitter
Alarm relays	<ul style="list-style-type: none"> • One fail-safe fault relay • Two standard form C relays SPDT, rated for 3 A at 250 VAC/30 VDC • Set to any level within the range of the instrument; programmable from the front panel
Alarm set point repeatability	±0.2°F (±0.1°C) dew point
Datalogger	32 GB capacity with MicroSD card, 2 GB card included
Display	128 x 64 matrix LCD
Display functions	Dew point temperature in °F or °C, ppmv with a constant pressure input, or sensor signals for diagnostics
Power requirements	Universal power 100-240 VAC @ 50-60 Hz 24VDC option available
Temperature	<ul style="list-style-type: none"> • Operating: -20° to 60°C (-4° to 140°F) • Storage: -40° to 70°C (-40° to 158°F)
Warm-up time	Meets specified accuracy within three minutes

* Refer to dew.IQ and IQ.probe data sheets for complete specification details

Start-up procedure

- Insert moisture probe into the sample cell
- Start with the inlet valve and the valve on rotameter fully closed
- For dew points at process pressure, slowly open the inlet valve until fully open; then crack the valve on the rotameter to get flow on scale
- For dew points at atmospheric pressure, fully open the valve on the rotameter; then crack the inlet needle valve on the rotameter to get flow on scale

Shut-down procedure

- Slowly close the inlet needle valve
- Slowly open the valve on the rotameter until the pressure on the pressure gauge is 0 psig
- Remove the moisture probe

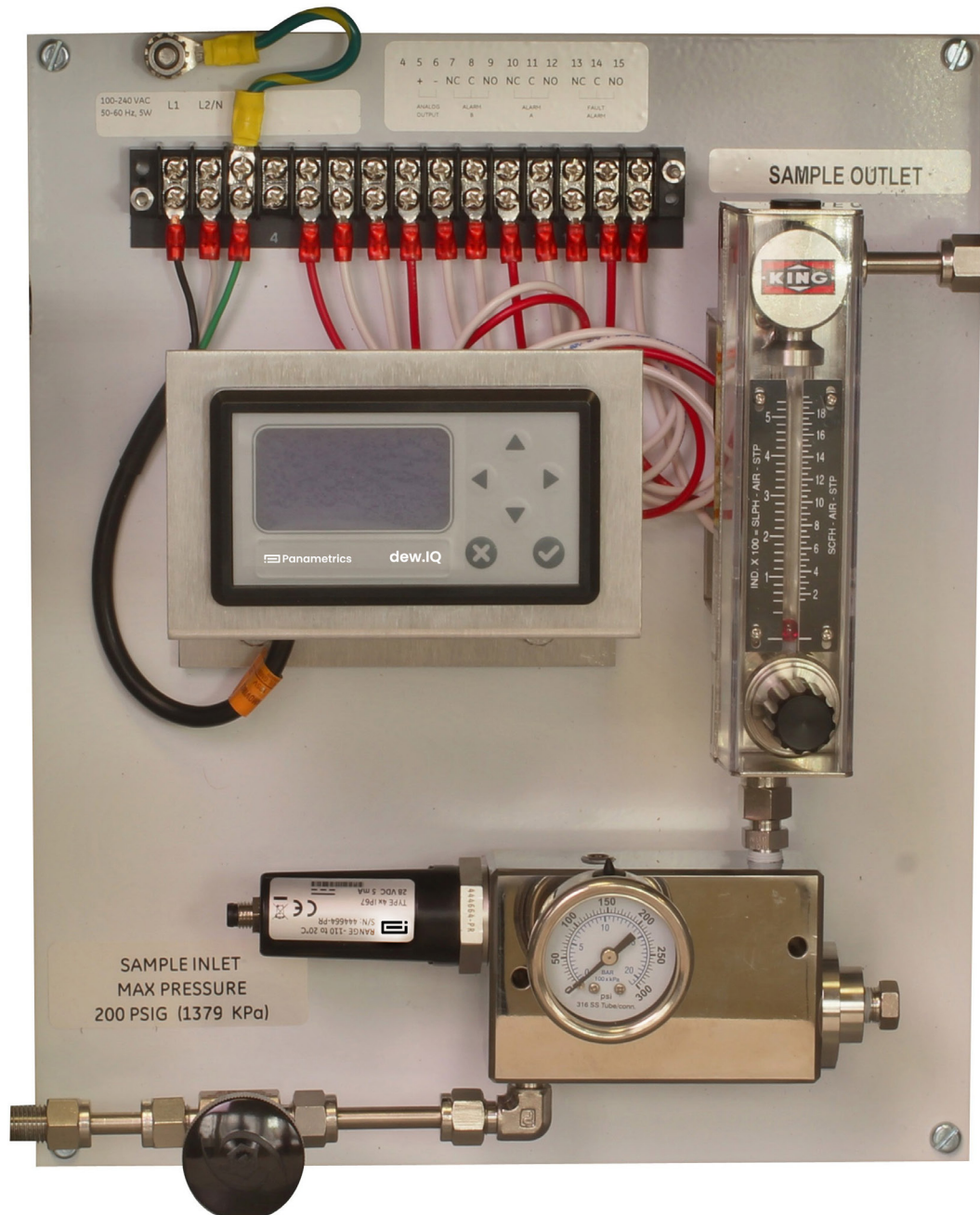

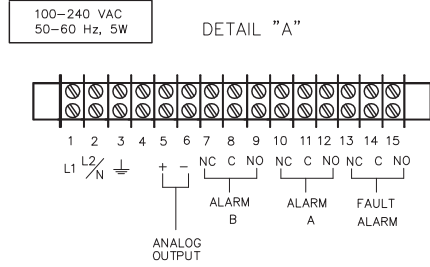

LABEL, SAMPLE SYSTEM,
DEW.IQ OUTPUTS

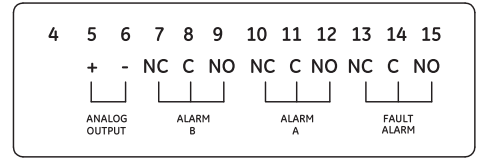

LABEL, SAMPLE SYSTEM,
DEW.IQ, POWER STRIP

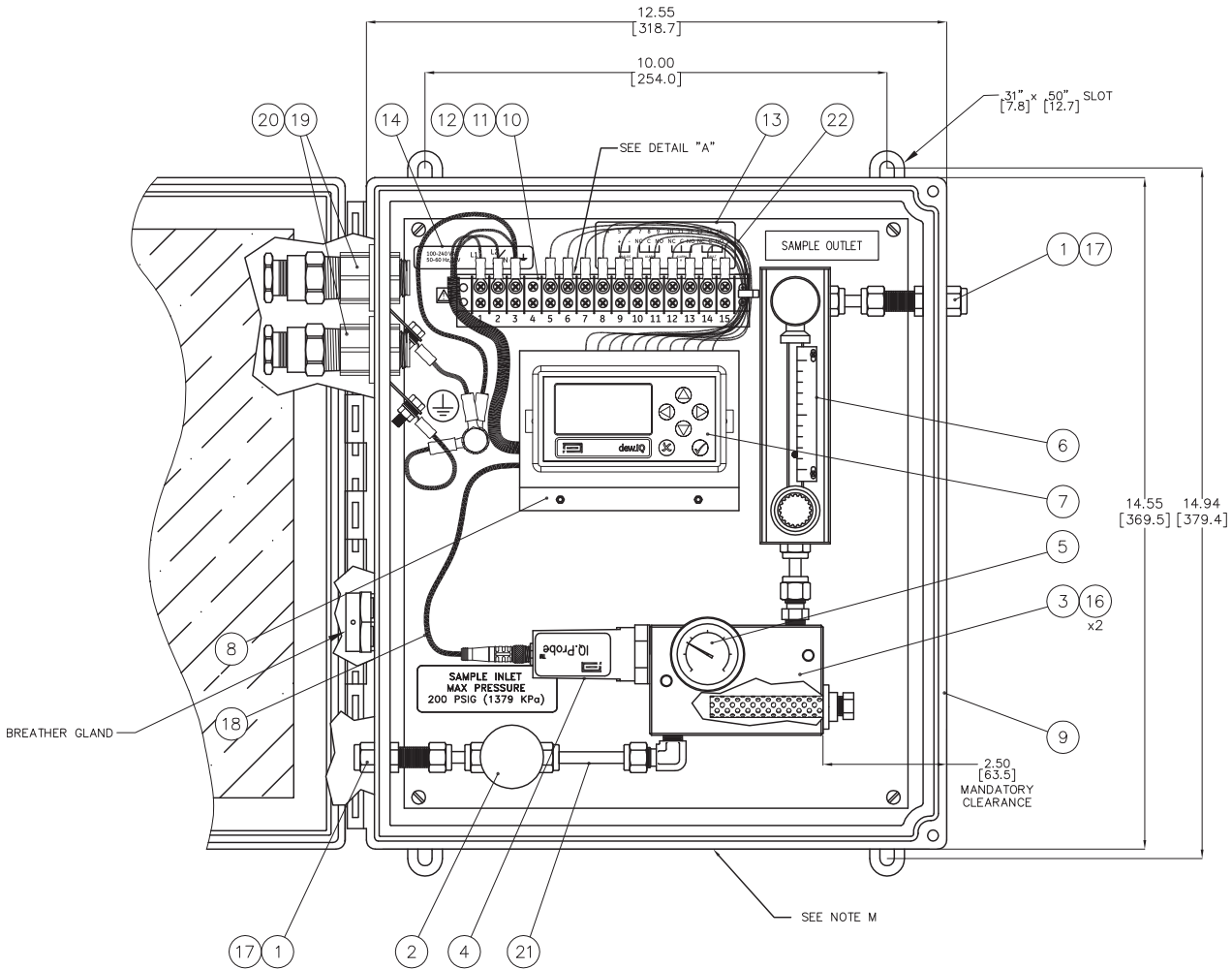
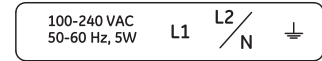

NOTES

- A) PROCESS CONNECTIONS: 1/4" TUBE FITTINGS.
- B) PROCESS TUBING : 1/4" x 0.035" SS 316L
- C) REF. BM: 733-1155-00
- D) DIMS : INCH [MM]
- E) APPROX WEIGHT : 22lbs [10kg]
- F) ELECTRICAL CONNECTIONS : 1/2" NPTF CONDUIT HUBS WITH OPTIONAL CABLE GLANDS
- G) WIRE PER LOCAL CODES AND STANDARDS
- H) ENCLOSURE DEPTH : 8.0 [203.2]
- I) PTFE TAPE USED ON ALL NPT FITTINGS
- J) SELF ADHESIVE LABELS FOR ALL PROCESS TAGGING
- K) PART/ASSEMBLY SHALL BE MADE FROM RoHS COMPLIANT MATERIALS
- L) AREA CLASSIFICATION : GENERAL PURPOSE (SAFE AREA)
- M) ADHERE S/N LABEL AND ITEM 15 TO BOTTOM INSIDE OF ENCLOSURE
- N) INCLUDES DEW.IQ-3-6-1-0 (146M5237) AND IQ.PROBE-2-W-0-0-0-0 (146M5241)
- O) AMBIENT TEMPERATURE : +23 TO +125°F (-5° TO +52°C)

WIRING DIAGRAM

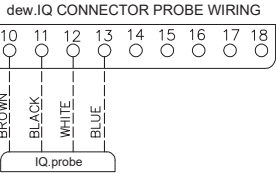
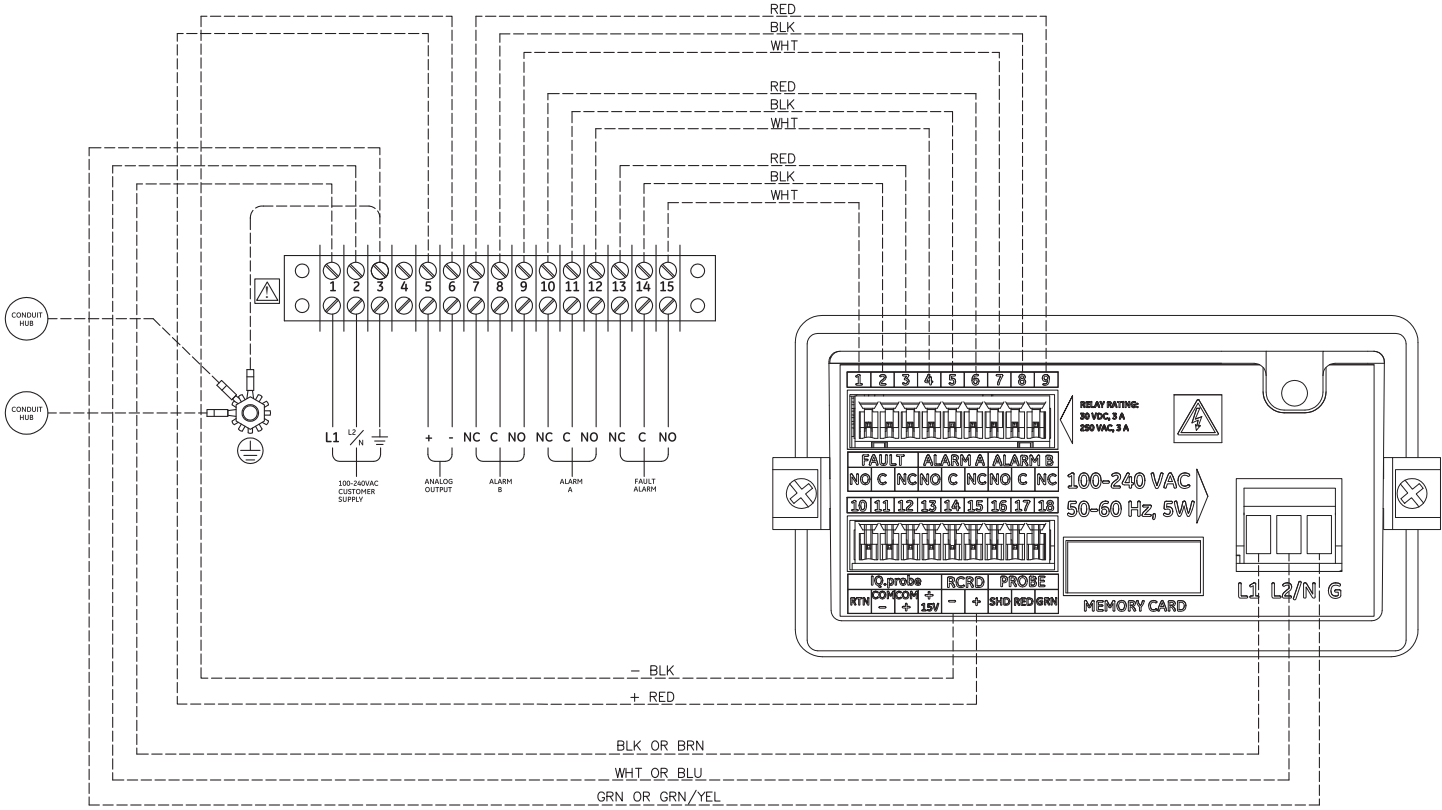

DEW.IQ REAR VIEW

- NOTES:
1. DASHED LINES INDICATE WIRING BY BAKER HUGHES
 2. WIRING PER LOCAL ELECTRICAL STANDARDS

BILL OF MATERIALS

		Shannon - Ireland Billerica - MA		DRAWN J.R. 25-OCT-12	APPROVED T.K. 25-OCT-12	ECM 500000348343	SAMPLE SYSTEM BILL OF MATERIAL air.IQ-1-1 AC VERSION 1/4" IMPERIAL FITTINGS		BM BM733-1155-00	REV D	
				CHECKED E.J. 25-OCT-12							
				DWG ITEM	INTERNAL REF.	PART NO.	DESCRIPTION	MFG.	MFG. PART No.	QUANTITY	COMMENTS
				1	UB14	750-2337	UNION BULKHEAD ASSY, 316SS, 1/4" COMPRESSION, WITH SELF-SEALING WASHER NEMA TYPE 4X & 6, IP66/68	SWAGELOK CO.	SS-400-61	2	
2	035	255-184	VALVE, NEEDLE, 5000 PSI (344 BARG), 316SS, 1/4" COMPRESSION ENDS	SWAGELOK CO.	SS-1RS4	1					
3		750-2123-00	AIR.IQ SAMPLE CELL ASSEMBLY, 5000 PSIG RATED, 316SS, INCLUDES FILTER ELEMENT, PVDF FLOUROCARBON, +99.5% EFFICIENT AT REMOVAL OF 0.1 MICRON PARTICLES & AEROSOLS, 1/4" COMPRESSION FITTINGS - 1 X MALE CONNECTOR/1 X MALE ELBOW	PANAMETRICS		1					
4		146M5241	IQ PROBE, 3/4"-16 PROBE MOUNT, W SHIELD (SS), STANDARD CALIBRATION -110° TO +20°C DATA	PANAMETRICS	IQ.PROBE-2-W-0-0-0-0-0	1					
5	136D	443-069-10	GAUGE, PRESSURE, 1-1/2" (40MM), 316 SS, ± 2.5 % of span (ASME B40.1 Grade C, EN 837-1 Class 2.5, JIS B7505 Class 2.5), AMBIENT OPERATING TEMP. -40 to 140°F (-40 to 60°C), 1/8" NPTM CENTRE BACK MOUNT, RANGE 0 to 200 PSI/BAR	SWAGELOK CO.	PGI-40M-PG200-CANX	1					
6	098B	750-414	FLOWMETER ASSY, BOROSILICATE GLASS METERING TUBE, 200 PSIG RATED, COMPLETE WITH 316L SS INTEGRAL INLET FLOW CONTROL VALVE, FLOW RANGE 1.9 to 19.5 SCFH / 54 to 540 SLPH, CAL AIR @ STP, 316L SS FITTINGS, SAPPHIRE FLOAT AND VITON 'O' RING, AMBIENT TEMP 33°F to 125°F (1°C to 52°C), 2 x 1/4" MALE ELBOWS	KING INSTRUMENT CO	74C214G021223910	1					
7		146M5237	DEW.IQ MOISTURE ANALYSER, PANEL MOUNT PACKAGE, 100-250VAC, STANDARD PROGRAM	PANAMETRICS	DEW.IQ-3-6-1-0	1					
8		418-200	MTS6 / DEW IQ MOUNTING BRACKET	DIMARK SHEET	ORDER BY DESC	1					
9	H185Q	750-2353	ENCLOSURE ASSY, FIBREGLASS WITH WINDOW, HINGED COVER, 14"x12"x8", NEMA/EEMAC Type 4, 4X, 12, 13 CSA File No. 42186; Type 4, 4X, 12, 13, IEC 60529, IP66, UL 508A LISTED, INCLUDES MOUNTING PLATE RAL6033 AND BREATHER GLAND (NEMA 4X & IP66 RATED)	HOFFMAN ENGINEERING CO.	A14128CHQRFGW	1					
10		213-2000	BARRIER BLOCK, 15 POS., INSULATION MATERIAL: MOLDED MONOBLOCK, GENERAL PURPOSE PHENOLIC, BLACK, UL RATED 94V-1, OPERATING TEMP -55° TO +300°F, VOLTAGE RATING 250 VAC MAX., CURRENT RATING 15 AMPS MAX.	CINCH	15-140	1					
11		213-2001	TERMINAL BLOCK MARKER, 1 TO 15, FOR 140 SERIES BARRIER BLOCK	CINCH	MS-15-140	1					
12		421-2520	TERMINAL COVER FOR 15 PIN TERMINAL BLOCK, FR4 GLASS EPOXY 0.031" THICK	EVANS MACHINE CO., INC.	FABRICATED	1					
13		442-1036	LABEL, SAMPLE SYSTEM, MTS5, OUTPUTS			1					
14		442-1345	LABEL, SAMPLE SYSTEM, MTS6 POWER STRIP			1					
15		442-1355	SUB COMPONENT LABEL			1					
16		148M2218	SPACER UNTHREADED SS 13MM DIA.X22MM LENGTH FOR M6 BOLT	McMASTER-CARR	92871A352	2					
17		410-2006	GREEN VINYL CAP P/N VC-562-8			2					
18		230-098	CABLE, 4 x 26 AWG CONDUCTORS + SHIELD (BROWN/WHITE/BLUE/BLACK), M8 CONNECTOR, 24VDC RATED, BLACK OUTER SHEATH Ø4.2, 0.3 METRE LENGTH	TURCK INC.	PKG 6M-0-3/CS10922	1					
19	CG1BNP	419-087	CABLE GLAND, UNARMoured, BRASS, NICKEL PLATED - 1/2"NPT SUITABLE FOR CABLE WITH OUTER DIA 4 - 8.4MM, ATEX: II 2 GD Ex d IIC / Ex e II (BAS 01ATEX1272X & SIRA 09ATEX1221X), IIECEX : Ex d IIC / Ex e II / Ex ID A21 (SIR 07.0096X), NEC CL I ZONE 1 (CSA 2627370), EAC Exd IICU (RU C-GB.Г506.B.00098)	PEPPERS	A2LBF/NP/16/050NPT	2					
20		419-943	CONDUIT HUB, MATERIAL : ZINC, CONDUIT CONNECTION: 1/2" NPTF, UL LISTED/CSA CERTIFIED	McMASTER-CARR	7513K81	2					
21		255-440	TUBING, 316/316L SEAMLESS STAINLESS STEEL, 1/4" X .035" WALL, NACE COMPLIANT, MATERIAL CERTIFICATION TO EN10204 3.1	SWAGELOK CO.	SS-T4-S-035-20	0.2					
22		750-2357-00	CABLE ASSEMBLY FOR AIR.IQ SIGNALS / VAC POWER, INCLUDING EARTHING	PANAMETRICS		1					
REV	ECM NO.	APPD/DATE	REV	ECM NO.	APPD/DATE	REV	ECM NO.	APPD/DATE	NOTES		
A	08805	10-SEP-2013							REF. DRAWING : 733-1155		
B	09129	24-OCT-2014									
C	500000284659	13-MAR-2018									
D	500000348343	13-MAY-2020									

Join the conversation and follow us on LinkedIn
[linkedin.com/company/panametricscompany](https://www.linkedin.com/company/panametricscompany)

Copyright 2024 by Panametrics LLC. All rights reserved.

PANA087DS_R6 (05/2024)



panametrics.com